

NEW LEVEL OF EFFICIENCY
FOR R134a APPLICATIONS

R134a
NLE-MF.2 COMPRESSORS

≥ 2 COP

@ -10/45 °C, EN 12900 MBP
@ - 6.7/54.4 °C, ASHRAE MBP



ON AVERAGE **25%**
MORE EFFICIENCY

NEW NLE-SERIES WITH 25% MORE EFFICIENCY FOR R134a APPLICATIONS

The major markets are developing at a fast pace to the hydrocarbons (HC) adoption. However, some markets and some specific applications will still require R134a solutions in a medium term.

Nidec GA Compressors introduces a new NLE-series of compressors with a focus on the refrigerant R134a. The new series provides a cost-efficient solution for smaller

OEMs and distributors that need to speed up and comply with efficiency labelling programs around the world.

Where specific or existing applications cannot be converted to high-end hydrocarbon solutions – ie. R600a and R290 – but high energy efficiency is still required, the NLE compressors are the obvious choice.

With improved design the NLE-R134a com-

pressors come with an average of 25% higher efficiency and lower displacements compared to already existing models. This ensures a new and better level of performance. The new NLE series is developed for MBP application, produced with copper connectors and is compatible with capillary tube or expansion valve (HST – High Starting Torque applications).

Current Options	Capacity [W] ASHRAE MBP	COP [WW] ASHRAE MBP		New NLE-MF.2 Equivalent Options	Capacity [W] ASHRAE MBP	COP [WW] ASHRAE MBP
• NL10MF	567	1.66	→	• NLE10MF.2	605	2.06
• NL11MF	623	1.62		• NLE11MF.2	687	2.04
• SC12G	612	1.61		• NLE12.6MF.2	747	2.09
new capacity range						
• SC15G	742	1.58				
• SC15MFX	782	1.68				

General	NLE10MF.2	NLE11MF.2	NLE12.6MF.2
Code number	105G6187	105G6197	105G6387
Approvals	EN 60335-2-34 w. Annex AA	EN 60335-2-34 w. Annex AA, CCC	EN 60335-2-34 w. Annex AA, CCC

Application	NLE10MF.2	NLE11MF.2	NLE12.6MF.2
Application	LBP/MBP	LBP/MBP	LBP/MBP
Evaporating temperature °C	-35 to 10	-25 to 10	-35 to 10 (50 Hz) -35 to 0 (60 Hz)
Voltage range/frequency V/Hz	198 - 254/50	198 - 254/50 (242 w/o run capacitor)	187 - 254/50, 198 - 254/60

Performance data ASHRAE LBP ASHRAE MBP (220 V/50 Hz • fan cooling • run capacitor • ePTC)									
Evaporating temperature °C		-23.3	-6.7	-23.3	-6.7	-23.3 (50/60 Hz)	-6.7 (50/60 Hz)		
Cooling capacity W		289	605	335	687	361	435	747	899
Power consumption W		189	294	221	337	233	278	358	427
COP W/W		1.53	2.06	1.52	2.04	1.55	1.56	2.09	2.11
Test conditions	Condensing temperature: LBP: 54.4°C, MBP: 54.4°C Suction gas temperature: LBP: 32.2°C, MBP: 35°C Ambient temperature: LBP: 32.2°C, MBP: 35°C Liquid temperature: LBP 32.2°C, MBP: 46.1°C								

Performance data EN 12900 LBP EN 12900 MBP (220 V/50 Hz • fan cooling • run capacitor • ePTC)									
Evaporating temperature °C		-25	-10	-25	-10	-25 (50/60 Hz)	-10 (50/60 Hz)		
Cooling capacity W		281	544	315	619	339	409	679	818
Power consumption W		185	268	211	311	228	272	335	400
COP W/W		1.52	2.03	1.49	1.99	1.49	1.50	2.02	2.04
Test conditions	Condensing temperature: LBP: 40°C, MBP: 45°C Suction gas temperature: LBP: 20°C, MBP: 20°C Ambient temperature: LBP: 32°C, MBP: 32°C Liquid temperature: LBP 40°C, MBP: 45°C								

Dimensions			
Height	mm	A	203
		B	197
Suction connector	location/I.D. mm angle	C	8.2 15°
	material seal		Copper Rubber plug
Process connector	location/I.D. mm angle	D	6.2 25°
	material seal		Copper Rubber plug
Discharge connector	location/I.D. mm angle	E	6.2 21°
	material seal		Copper Rubber plug
Connector tolerance	I.D. mm		±0.09

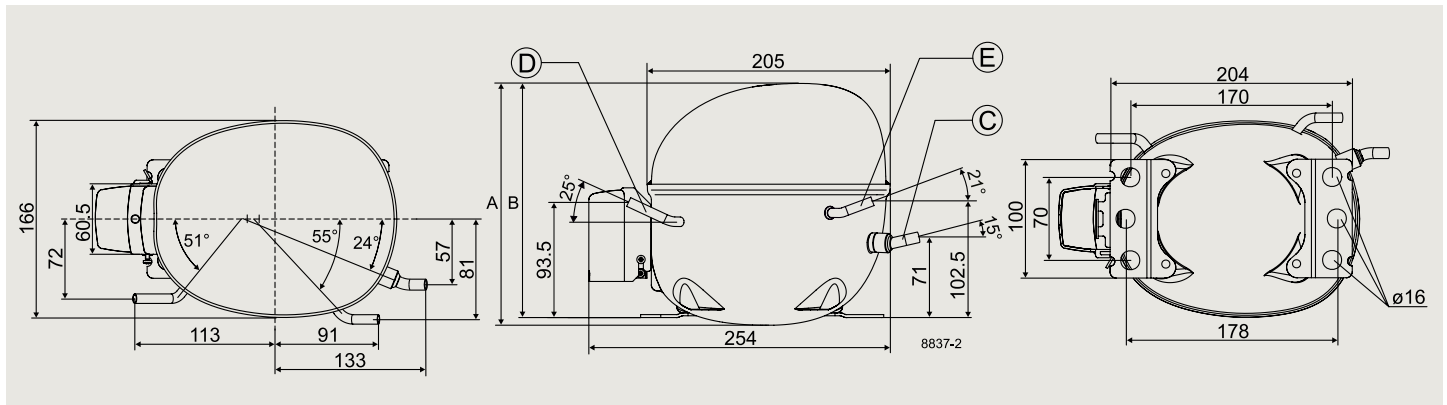

Nidec Global Appliance Germany GmbH · Mads-Clausen-Str. 7 · 24939 Flensburg · Germany · Tel: +49 461 4941 0 · www.secop.com

Nidec GA Compressors accepts no responsibility for possible errors in catalogs, brochures, and other printed material. Nidec GA Compressors reserves the right to alter its products without notice. This also applies to products already on order provided that such alterations can be made without subsequent changes being necessary to specifications already agreed. All trademarks in this material are the property of the respective companies. Secop and the Secop logotype are trademarks of Nidec Global Appliance Germany GmbH. All rights reserved.

Produced by Nidec Global Appliance Germany GmbH | October 2017

DES.N.400.A2.02