

## Model

Designation	<b>NLE8.8CN</b>	115-127V/60Hz 1~	Sales code:	<b>105H6096</b>
-------------	-----------------	------------------	-------------	-----------------

## Compressor design

Oil type	Polyolester	Refrigerant(s)	<b>R290</b>
Oil viscosity	19,2cSt	Displacement	8,76cm <sup>3</sup> / 0,53cu.in
Oil quantity	301cm <sup>3</sup> / 10,2fl.oz	Compressors on pallet	80
Refr. charge - tech. limit	150g / 5,3oz		
Free gas volume comp.	2360cm <sup>3</sup> / 79,8fl.oz		
Weight	10,9kg / 24lbs		
Motor protection	1# internal		
Winding resistance main	1,6Ω (at 25°C)		
Winding resistance aux	5,1Ω (at 25°C)		
Max. winding temp.	125°C / 257°F		
Max. discharge temp.	120°C / 248°F		



## General - Configurations with NLE8.8CN

	<b>Conf. 1</b>
Motorconfiguration	CSIR
Power supply (nominal)	115V/60Hz
Number of phases	1
Voltage range	95-135V
Approvals	UL
Starting torque	HST
Note	Protector and relay are included and pre-assembled to compressor.

## Applications with NLE8.8CN

	<b>Conf. 1</b>
Refrigerant	R290
Application	LBP+MBP
System cooling	fan 3m/s
Hot gas defrost	OK
Long interval pull down	OK

## Electrical data - Configurations with NLE8.8CN

	<b>Conf. 1</b>
Starting device type	relay
Run capacitor	0μF
Start capacitor	240μF
LRA (locked rotor amps / 4s)	32,01A
RLA (rated load amps / 1s)	5,33A
Cut in current	32,01A
IP class	21

## Model

Designation

**NLE8.8CN**

115-127V/60Hz 1~

Sales code:

**105H6096**

## Compressor dimensions

Housing	A Height	203mm / 7,99in
	B Height	197mm / 7,76in
	C Length shell	205mm / 8,07in
	D Length w. cover	254mm / 10in
	E Width	166mm / 6,54in

Connectors		Suction	Discharge	Process
		X	Y	Z
Diameter	[mm]	øi 8,11-8,29	øi 6,41-6,59	øi 6,41-6,59
	(i:inside, o:outside) [in]	øi 0,32-0,33	øi 0,25-0,26	øi 0,25-0,26
Material		copper	copper	copper
Horizontal angle	±2°	22°	0°	0
Vertical angle	±2°	45°	35°	155°
Position l/h/w	[mm]	128/79/61	88/95/85	-112/97/68
	[in]	5/3,1/2,4	3,5/3,7/3,3	-4,4/3,8/2,7
Straight tube l.	[mm]	12	12	12
	[in]	0,5	0,5	0,5

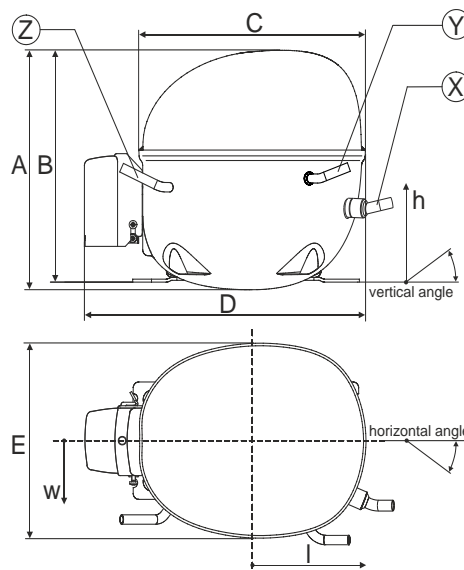

## Compressor fixation

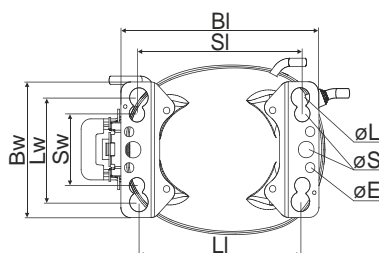

Baseplate	[mm]	[inch]
BI	204	8.03
Bw	132	5.2
øE	ø 9.7	ø 0.38
Large holes	[mm]	[inch]
LI	165	6.5
Lw	101.6	4
øL	ø 19	ø 0.75
Small holes	[mm]	[inch]
SI	170	6.7
Sw	70	2.76
øS	ø 16	ø 0.63

### Bolt joint

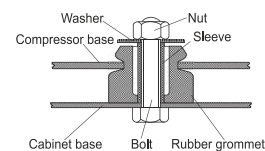

### Snap-on

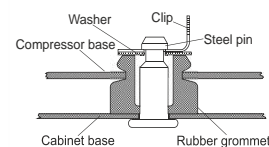

## Mounting accessories

	one comp.	multi pack
Bolt joint   M6   ø16mm	118-1917	118-1918
Bolt joint   ø1/4"   ø16mm	118-1946	
Bolt joint   ø1/4"   ø19mm	118-1949	
Snap-on   ø7,3   ø16mm	118-1947	118-1919

### Model

Designation	<b>NLE8.8CN</b>	<b>115V/60Hz</b>	<b>Conf. 1</b>	Sales code:	<b>105H6096</b>
-------------	-----------------	------------------	----------------	-------------	-----------------

### Configuration

Motorconfiguration	CSIR	
Power supply (nominal)	115V/60Hz 1~	
Refrigerant	R290	
Application	LBP+MBP	
Voltage range	95-135V	
Starting torque	HST	
Approvals	UL	SA3693

### Electrical accessories / wiring diagram

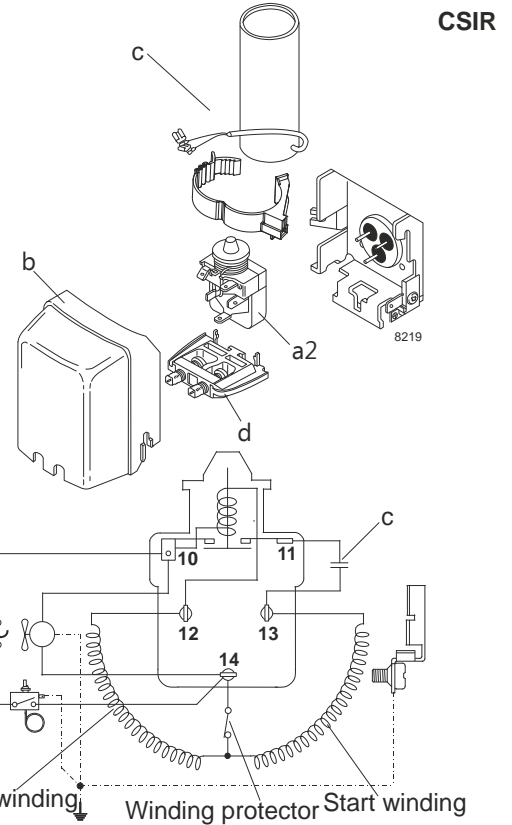

### Ambient temperatures / system cooling

Ambient temperature min.:	10°C / 50°F
Ambient temperature max.:	43°C / 110°F

System cooling			
T ambient	LBP	MBP	HBP
32°C / 90°F	fan 3m/s	fan 3m/s	n/a
38°C / 100°F	fan 3m/s	fan 3m/s	n/a
43°C / 110°F	fan 3m/s	fan 3m/s	n/a

### Operation pressure range

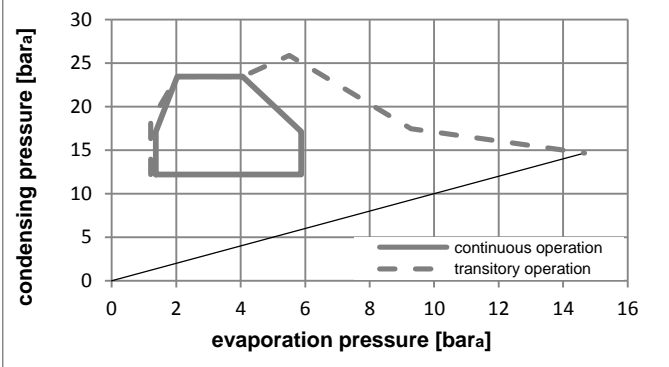
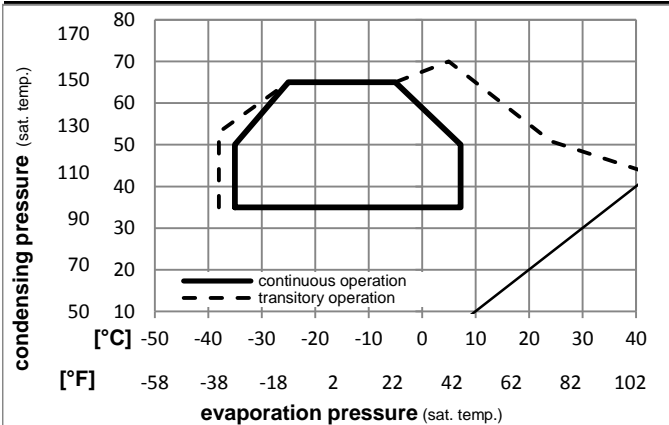

### Components:

a2	current relay	117U7014
c	start capacitor (280µF)	117U5025
b	plastic cover	103N2011
d	cord relief	103N1010

## Model

Designation **NLE8.8CN 115V/60Hz** Conf. 1 Sales code: **105H6096**

## Optimization + standard conditions

115V/60Hz 1~, CSIR, fan 3m/s, UL

	Evaporating pressure (saturation temperature)				Condensing pressure (saturation temperature)						Power consumption			ASHRAE LBP
	pe	pc	RGT	Tliq	Cooling capacity			COP	EER	P1	I	Ref. mass flow		
	[°C]	[°F]	[°C]	[°F]	[W]	[Btu/h]	[kcal/h]	[W/W]	[Btu/Wh]	[kcal/Wh]	[W]	[A]	[kg/h]	
	-23,3	54,4	32,2	32,2	512,6	1751	441,2	1,57	5,37	1,35	325,8	4,24	5,19	ASHRAE LBP
	-10	130	90	90										
	-25	55	32	55	384,4	1313	330,8	1,22	4,16	1,05	315,7	4,18	4,79	cecomaf LBP
	-13	131	89,6	131										
	-35	40	20	40	304,3	1039	261,9	1,26	4,30	1,08	241,7	3,80	3,48	EN12900 LBP
	-31	104	68	104										
	-6,66	54,4	35	46,1	915,3	3126	787,7	2,08	7,11	1,79	439,5	5,00	10,44	ASHRAE MBP
	20	130	95	115										
	-10	55	32	55	728,1	2486	626,6	1,75	5,98	1,51	416,1	4,83	9,21	cecomaf MBP
	14	131	89,6	131										
	-10	45	20	45	807,7	2758	695,1	2,08	7,10	1,79	388,3	4,64	9,92	EN12900 MBP
	14	113	68	113										

## Performance tables

115V/60Hz 1~, CSIR, fan 3m/s, UL

	pe	Cooling capacity			COP	EER	P1	I	m		
	[°C]	[°F]	[W]	[Btu/h]	[kcal/h]	[W/W]	[Btu/Wh]	[kcal/Wh]	[W]	[A]	[kg/h]
[°C / °F]	-35	-31	288,9	987	248,6	1,18	4,02	1,01	245,5	3,83	3,24
cond. pressure	-23,3	-10	493,0	1684	424,3	1,60	5,46	1,37	308,7	4,15	5,57
pc= 45/113	-15	5	695,8	2376	598,8	1,95	6,68	1,68	356,0	4,43	7,92
return gas temp.	-9,4	15	858,1	2931	738,5	2,19	7,47	1,88	392,1	4,67	9,82
RGT= 32/90	-3,9	25	1042,6	3561	897,3	2,40	8,20	2,07	434,1	4,96	12,02
liquid temp	0	32	1185,3	4048	1020,1	2,53	8,65	2,18	468,0	5,20	13,75
Tliq= 45/113	7,2	45	1480,2	5055	1273,8	2,72	9,31	2,34	543,2	5,74	17,39
[°C / °F]	-35	-31	239,4	818	206,0	0,97	3,32	0,84	246,6	3,83	2,96
cond. pressure	-23,3	-10	415,0	1417	357,2	1,27	4,34	1,09	326,6	4,24	5,17
pc= 55/131	-15	5	596,3	2036	513,2	1,56	5,34	1,35	381,3	4,59	7,50
return gas temp	-9,4	15	743,8	2540	640,1	1,77	6,05	1,52	420,2	4,86	9,42
RGT= 32/90	-3,9	25	913,1	3118	785,8	1,97	6,73	1,70	463,2	5,19	11,65
liquid temp	0	32	1044,9	3568	899,2	2,10	7,18	1,81	496,7	5,45	13,42
Tliq= 55/131	7,2	45	1319,0	4505	1135,2	2,32	7,92	2,00	569,0	6,04	17,18